



INSTALLATION & OPERATION MANUAL

EVO MAX

COMMERCIAL HOT WATER HEAT PUMP



Contents

1. Introduction	2
2. Dimensions	3
3. Safety Instructions	4
4. Installation.....	5
4.1 Transit	5
4.2 Location of Installation	5
4.3 Airflow Clearances	5
4.4 Plumbing	6
4.5 Electrical Connection	6
4.6. Initial Start-Up	7
5. Operation	8
5.1 The Controller	8
5.2 Operating Functions.....	8
5.2.1 On/Off.....	8
5.2.2 Setting the Target Temperature	8
5.2.3 Unit Selection	8
5.2.4 Locking the Screen.....	8
5.2.5 Setting a Timer	9
5.2.6 Settings.....	9
6. Troubleshooting	11
7. Appendix.....	12
7.1 Parameter List.....	12
7.2 Cable Specifications.....	12
7.3 Wire Control Interface Diagram.....	12
7.4 Wiring Diagrams.....	13
8. Maintenance	15
9. Warranty	16

1. Introduction

This manual contains information relating to the installation, troubleshooting, operation, and maintenance of this EvoHeat unit. Instructions in this manual must always be followed. Failure to comply with these recommendations will invalidate the warranty. Should you have any questions or require technical support, call the EvoHeat office on 1300 859 933 to speak to our team.

The data and information contained in this manual is correct at the time of publishing and is subject to change without notice. For the most up to date manual, contact EvoHeat directly.



The Evo Max is ideal for commercial water heating applications that need high temperature hot water of up to 80°C. It is ideal for hospitals, nursing homes, hotels and motels, food preparation and sanitation, sterilization, industrial and laundry applications. With a higher C.O.P than traditional boilers, cutting edge technology, green refrigerants, high efficiency heat exchanger and a circulating heating method, the Evo Max can help end users save significantly on their annual hot water operating costs.

TECHNICAL DATA			Evo Max 19	Evo Max 35	Evo Max 70	Evo Max 135
Hot Water Conditions: Air 20°C, Water 65°C	Heating Capacity	kW	19	35	70	135
	Power Input	kW	5.3	9.2	19	38.6
	C.O.P		3.58	3.68	3.68	3.5
Hot Water Conditions: Air 20°C, Water 80°C	Heating Capacity	kW	16	29.5	58.9	113.7
	Power Input	kW	6	10.8	21.5	43.7
	C.O.P		2.67	2.74	2.74	2.6
Max. Running Current	A	14.3	32.2	64.6	103.85	
Max. Power Input	kW	7.5	18.1	36.2	52.96	
Voltage/Phase		380-415V/3/50	380-415/3/50	380-415/3/50	380-415/3/50	
Noise	dB(A)	58	65	68	70	
Air Discharge Type		Horizontal	Horizontal	Vertical	Vertical	
Fan No.		2	1	2	4	
Compressor No.		1	1	2	4	
Refrigerant Type		R134a	R134a	R134a	R134a	
Refrigerant Charge	g	4700	8000	11000	20000	
Operation Range	°C	-7 to 45	-7 to 45	-7 to 45	-7 to 45	
Hot Water Volume	L/hr	55	100	200	386.67	
Water Pressure Drop	kPa	25	38	42	96	
Water Connection	inch	DN32 Flange	DN40 Flange	DN65 Flange	DN80 Flange	
Max. Water Temp.	°C	80	80	80	80	
Net Weight	kg	238	468	600	1072	
Net Dimensions (L/W/H)	mm	1175 / 400 / 1605	1195 / 980 / 1900	1930 / 1050 / 1980	2350 / 1150 / 2370	

2. Dimensions

Evo Max 19

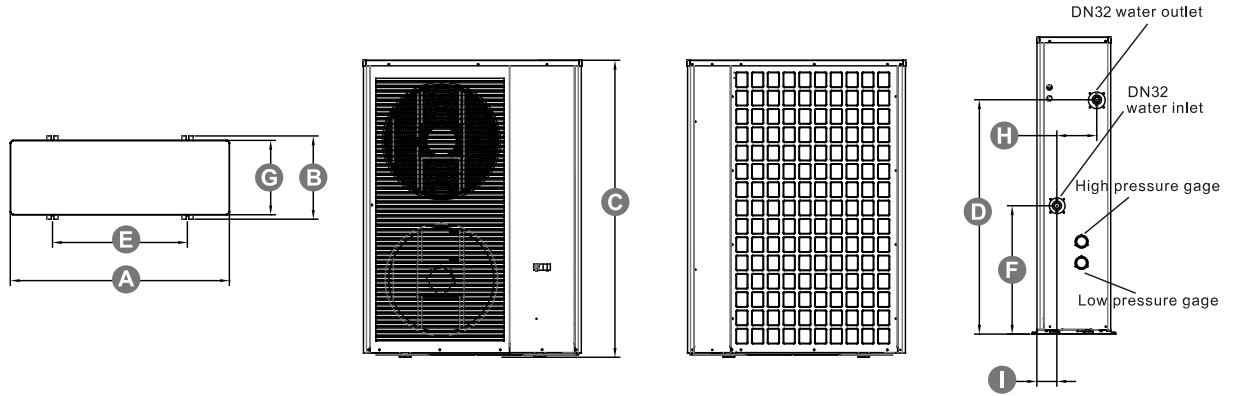

Evo Max	A (L)	B (W)	C (H)	D	E	F	G	H	I
19	1175	400	1605	1267	725	694	402	215	107

Evo Max 35

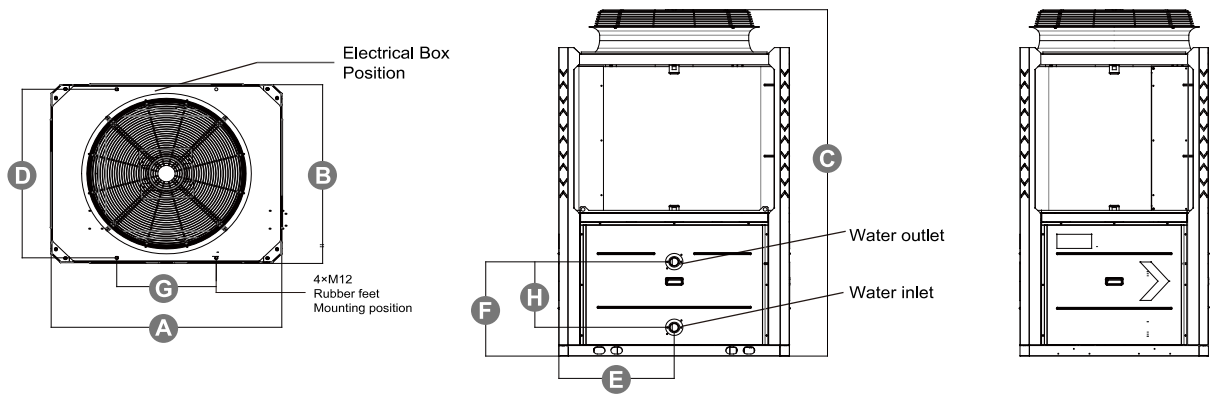

Evo Max	A (L)	B (W)	C (H)	D	E	F	G	H
35	1195	980	1900	925	598	517	516	360

Evo Max 70 & 135

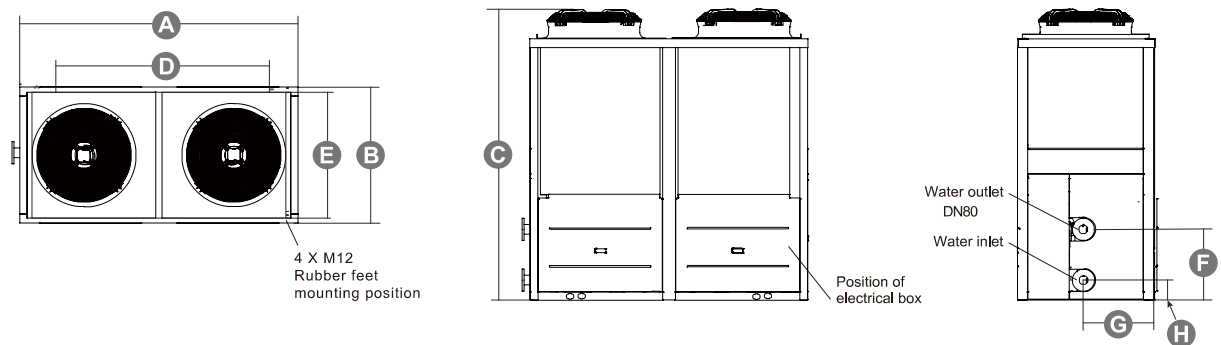

Evo Max	A (L)	B (W)	C (H)	D	E	F	G	H
70	1930	1050	1980	1170	998	539	530	170
135	2350	1150	2370	1590	1098	614	575	164

3. Safety Instructions

- Installation, repairs and maintenance of this unit must be performed by a qualified technician.
- Any wiring must comply with local electrical regulations.
- If any abnormal instances occur or a strange smells, the unit must be shut off by the power supply.
- Do not put fingers or objects into the fans or evaporator of the unit.
- The unit must be earthed to avoid any risk caused by insulation defects.
- No wiring must come into contact with the heat source or the rotating fan parts.
- The unit must be handled and lifted with appropriate equipment in correlation with the unit's size and weight.
- Electrical power must be switched off before any work is started on the unit.
- Do not expose the unit to or install near any flammable gases.
- Ensure there is a circuit breaker for this unit.
- Copper and iron can not be used as a fuse.
- The unit is equipped with an over-load protection system. After a previous stoppage, the unit will not start for at least 3 minutes.
- If the supply cord is damaged, it must be replaced by the manufacturer, our service agent or a similarly qualified person in order to avoid a hazard.
- USE SUPPLY WIRES SUITABLE FOR 75°C.
- Caution: Single wall heat exchanger, not suitable for potable water connection.



WARNING

THIS PRODUCT CONTAINS A BUTTON BATTERY

If swallowed, a lithium button battery can cause severe or fatal injuries within 2 hours.

Keep batteries out of reach of children.

If you think batteries may have been swallowed or placed inside any part of the body, seek immediate medical attention.

4. Installation

4.1 Transit

When transporting the unit, ensure the unit is kept standing upright. Laying the unit down may damage internal parts.

If the unit needs to be hung up (such as for lifting with a crane) use the special lifting hole (hook) on the base of the unit with an 8 metre cable. Ensure there is some kind of padding between the cable and the unit to prevent damage to the heat pump cabinet.

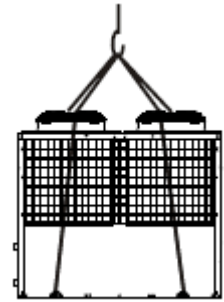

4.2 Location of Installation

The unit can be installed in any outdoor area which can carry the weight of heavy machinery, such as a terrace, rooftop, the ground etc.

- The location must have adequate ventilation and be free from strong winds.
- The installation location must be free from heat radiation and fire hazards.
- Ensure there are no obstacles near the air inlet and outlet of the heat pump.
- There must be a water channel around the heat pump to drain condensing water.
- Ensure that there is enough space around the unit for maintenance.
- The heat pump can be installed onto the concrete basement using expansion screws, or onto a steel frame with rubber feet which can be placed on the ground or rooftop. Ensure the unit is placed horizontally.

4.3 Airflow Clearances

Single Unit

1500mm overhead clearance

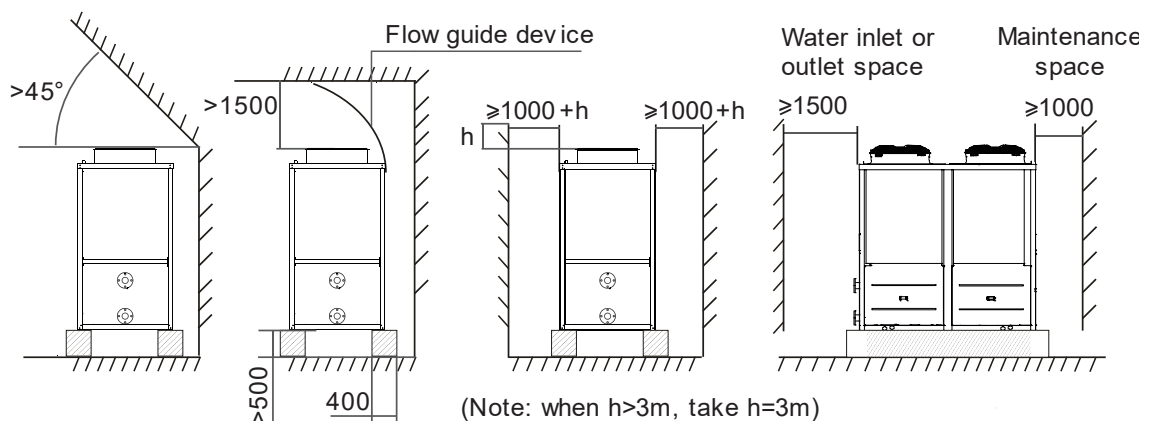

Multiple Units

1000mm clearance on all sides

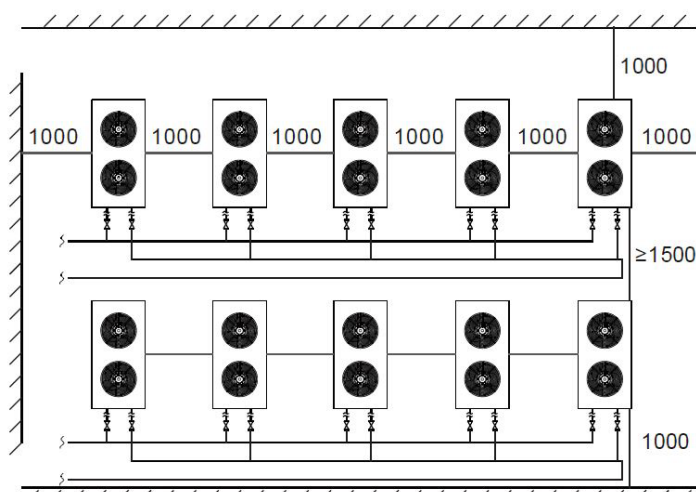

4.4 Plumbing

- Try to reduce the resistance to the water from the piping.
- The piping must be clear and free from dirt and blockage. A water leakage test must be carried out to ensure that there is no water leaking before the installation can be made.
- The pipe must be tested by pressure separately. DO NOT test it together with the unit.
- There must be an expansion tank on the top point of the water loop, and the water level inside the tank must be at least 0.5 meters higher than the top point of the water loop.
- The flow switch is installed inside of the heat pump, check to ensure that the wiring and action of the switch is normal and controlled by the controller.
- The connection between the heat pump and the construction is best to be of a flexible type to avoid vibration transfer. The support to the water pipe must be separate, but not rely on the heat pump unit.
- Try to avoid any air from being trapped inside the water pipe, there must be an air vent on the top point of the water loop.
- There must be a thermometer and pressure meter at the water inlet and outlet for easy inspection during running.
- There must be drainage on the low points of the water system, and there is already drainage on the chassis of the heat pump. The water in the system must be drained out during winter if the heat pump is not to be used.

4.5 Electrical Connection



Always use a suitably qualified Electrician to perform any electrical work, they must read the manual before connecting.

Ensure all cabling, circuit breakers, and protections are of a suitable size and specification in accordance with electrical wiring legislation for the heater being installed. Ensure to check that there is adequate voltage and current available at the heater connection to run the unit.

- Open the panel and open the power line hole
- Thread the power line through the hole and connect it to the power line terminal. The three-core control line of the remote controller shall be plugged with the three-core signal line on the main board according to the wiring diagram.
- For an external water pump, thread the power line of the water pump through the hole and connect it to the water pump terminals.
- If an additional auxiliary heater is needed to be controlled by the heat pump controller, the relay (or power) of the aux-heater must be connected to the relevant output of the controller.

ATTENTION:

- The unit should use an independent power supply, see wiring in *Cable Specifications*. Power supply voltage must be in line with the rated voltage.
- The power supply circuit must be equipped with an All-pole disconnect device and have at least 3mm contact opening distance.
- The wiring must be completed by a professional technician in accordance with the circuit diagram.
- Power supply circuit must have earth wire; the earth wire of power should be connected with an external earth wire safely. The external earth wire must be in order.
- The creepage protection device must be settled in accordance with the relevant national technical standards for electronic equipment.
- The power wire and signal wire should be neatly arranged. High voltage wires and low voltage wires must be separated and free from any interference. These wires must also be free from any pipes or valves on the unit.
- When all wiring is completed, the power should only be connected after a thorough double check.



Correct phase connection is important with 3 phase heaters. NOTE: if 2 lights are showing on the 3 PHASE relay monitor this means the EvoHeat heat pump has been wired correctly (one orange light and one green light). If only one light is showing, the phases are out of rotation and need to be rotated to get the correct phase rotation.

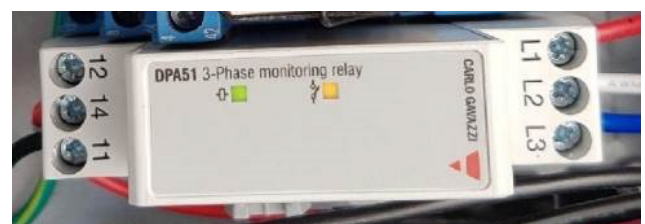

4.6. Initial Start-Up

Prior To:

Check the indoor unit, make sure that the pipe connection is done correctly and that the relevant valves are open.

Check the water loop to ensure that there is enough water inside of the expansion tank, that the water supply is good and that the water loop has no air in it and is full of water. Make sure there is good insulation for the water pipe.

Check the electrical wiring. Make sure that the power voltage is normal, the screws are fastened, the wiring is made in line with the diagram and the earthing is connected.

Check that the heat pump, including all the screws and different parts are in good order. When the power is on, review the indicator on the controller to see if there is any failure indications. The gas gauge can be connected to the check valve to see the high pressure (or low pressure) of the system during trial running.

Trial Operation:

Start the heat pump and check whether the water pump is running, if it is running normally there will be 0.2MPa on the water pressure meter.

When the water pump runs for 1 minute, the compressor will start. Hear whether there is a strange sound coming from the compressor. If an abnormal sound occurs, please stop the unit and check the compressor. If the compressor runs well, look for the pressure meter of the refrigerant.

Check whether the power input and running current is in line with the manual. If not stop the unit and check for why this may be occurring.

Adjust the valves on the water loop to make sure that the hot (cool) water supply to each door is good and meets the requirement of heating (or cooling).

Review whether the outlet water temperature is stable.

5. Operation

5.1 The Controller

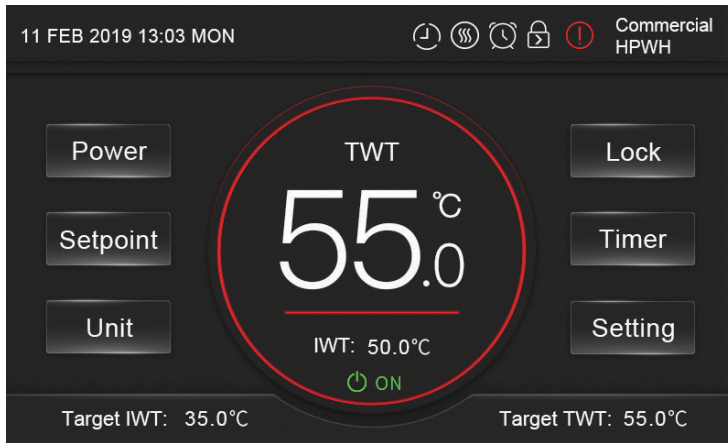

Power	Turn the unit on or off
Setpoint	Set the target temperature
Unit	Enter the unit state of the central control system for 4 units.
Lock	Lock or unlock the screen
Timer	Enter timer setting menu (Power Timer, Return Water Valve Timer, & Temp Timer)
Setting	Enter function menu (Parameter, Failure, Status Time, Electric Heating, Temp Curve)
Target IWT: 35.0 °C	Target temperature of inlet water
Target TWT: 55.0 °C	Target water tank temperature
11 FEB 2019 13:03 MON	Unit's set date & time
Display Circle	Red: Heating Mode, Grey: Off

Icons will appear at the top right of the screen indicating certain functions that are enabled, or if there has been an error with the system.

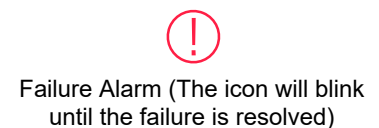
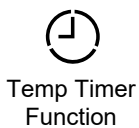

5.2 Operating Functions

5.2.1 On/Off

From the main menu, simply press the '**Power**' button to turn the unit on or off.

5.2.2 Setting the Target Temperature

To adjust the target temperature value, press the '**Setpoint**' button to enter the parameter setting screen.

Enter the required parameter according to the effective range which is displayed at the bottom of the screen.

5.2.3 Unit Selection

From the main menu, press the 'Unit' button to enter the unit status check of the central control system for 4 units.

5.2.4 Locking the Screen

From the main menu, press the '**Lock**' button to lock the controller screen and prevent unauthorised people accessing the controls.

When the screen is locked a small lock symbol will appear on the top right of the main menu.

To unlock the screen, press the '**Lock**' button again and enter the password **22** which will unlock the screen and remove the lock symbol.

5.2.5 Setting a Timer

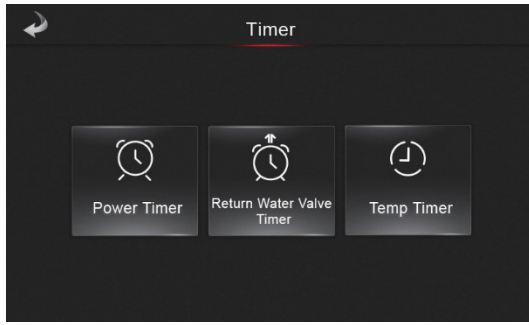

After pressing the 'Timer' button from the main interface, choose a timer type from the various options.

5.2.5.1 Power Timer

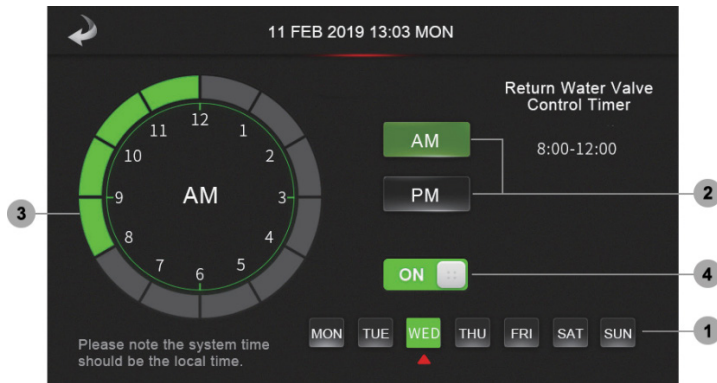

The **Power Timer** function allows you to set the opening time of the unit for each day of the week.

Press (1) to select the day of the week, then (2) to select AM or PM, after this press (3) to select the time, and lastly select (4) to enable or turn off the setting.

5.2.5.2 Return Water Valve Timer

The timing interface of the return valve is similar to that of the time switch machine.

5.2.5.3 Temperature Timers

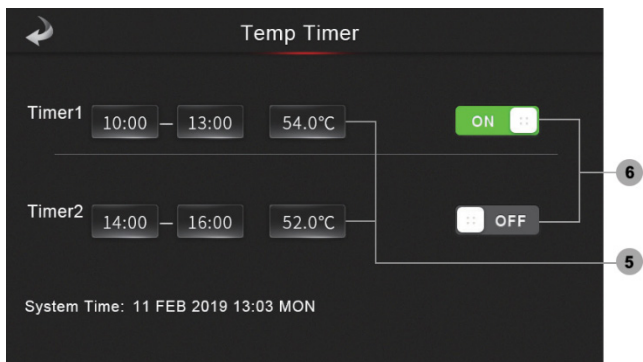

The **Temp Timer** function enables time-sharing temperature control, which is two segments of staggered peak temperature control, and allows the target temperature of two segments of different time periods to be set according to different modes.

Enter the start time, ending time and the target temperature setpoint value (5). Press (6) to enable or disable the settings.

5.2.6 Settings

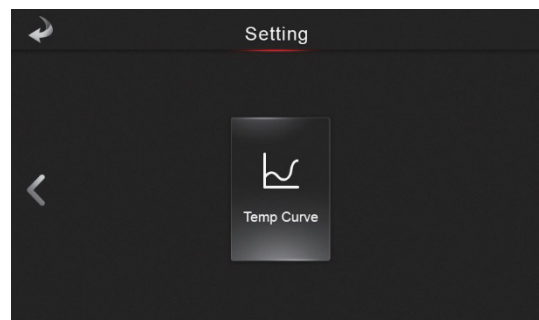
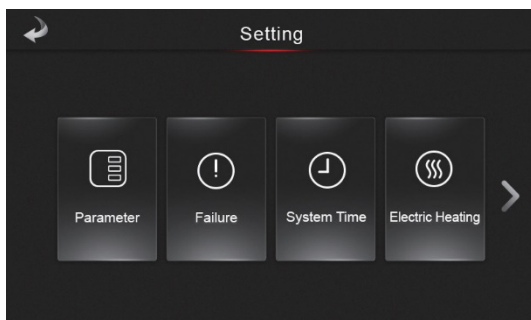

After pressing the 'Setting' button on the main menu, you can select from a range of functions.

5.2.6.1 Parameter

This function is only available for EvoHeat technicians during maintenance.

5.2.6.2 Failure

When a failure is present, the red failure alarm will be flashing on the main menu. First press '**Settings**' then '**Failure**' to view the failure records.

Once maintenance has been completed, press the 'clear' button to delete the failure history.

5.2.6.3 System Time

To change the system's date & time, click on the input field and enter the correct values. Press 'save' in the top right corner to save the settings.

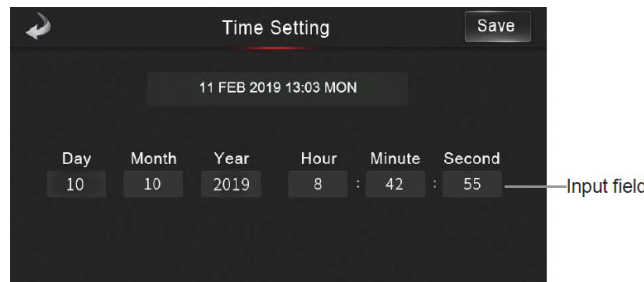

5.2.6.4 Electric Heating

In the settings menu, the Electric Heating option will display as 'OFF Electric Heating'. Make sure that the unit is firstly in heating mode, then press the electric heating button to head to its interface. Click the button to turn it on to activate the electric auxiliary heating mode. Turn off the function by tapping the button again.

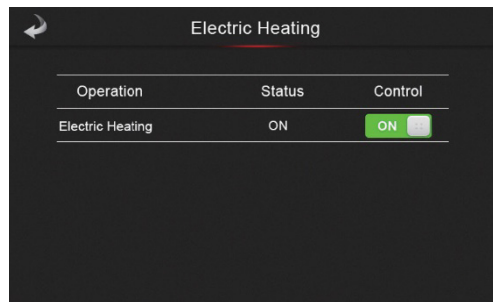

5.2.6.5 Temperature Curve

Press the **Temp Curve** to view the inlet/outlet temperature curve.

- This curve function records the water inlet outlet temperature.
- Temperature data is collected every 5 minutes, and the 12 sets of temperature data are saved every hour. Timekeeping is made from the latest data saving. If the power is disrupted before all 12 data sets have been collected the data will not be saved.
- Only curve for the electricity status is recorded, the outage status will not be saved.
- The value of the abscissa indicates the time from the point on the curve to the current time point. The leftmost point on the first page (0 on the abscissa is the latest temperature record).
- Temperature curve record is provided with power off memory function; in the case of a disturbed curve recording and display, when the unit is next powered on the wire controller will automatically clear the history curve record and the curve recording function will restore to a normal state.

6. Troubleshooting

Protect/fault	Fault	Reason	Elimination methods
Inlet Temp Sensor Fault	P01	The temp. Sensor is broken or short circuit	Check or change the temp. sensor
Outlet Temp Sensor Fault	P02	The temp. Sensor is broken or short circuit	Check or change the temp. sensor
Water Tank Temp Sensor	P03	The temp. Sensor is broken or short circuit	Check or change the temp. sensor
AT Sensor Fault	P04	The ambient temp. Sensor is broken or short circuit	Check or change the temp. sensor
Syst1:Coil temp1 Sensor	P153	The temp. Sensor is broken or short circuit	Check or change the temp. sensor
Syst1:Coil temp2 Sensor	P154	The temp. Sensor is broken or short circuit	Check or change the temp. sensor
Syst1:Suction temp Sensor	P17	The temp. Sensor is broken or short circuit	Check or change the temp. sensor
Syst1:Antifreeze Sensor1(US)	P191	The temp. Sensor is broken or short circuit	Check or change the temp. sensor
Syst1:Antifreeze Sensor2(US)	P193	The temp. Sensor is broken or short circuit	Check or change the temp. sensor
Syst1:Antifreeze Sensor4(HSS)	P195	The temp. Sensor is broken or short circuit	Check or change the temp. sensor
Syst1:Inlet Sensor(EVI)	P101	The temp. Sensor is broken or short circuit	Check or change the temp. sensor
Syst1:Outlet Sensor(EVI)	P102	The temp. Sensor is broken or short circuit	Check or change the temp. sensor
Syst1:Exhaust temp Sensor	P181	The temp. Sensor is broken or short circuit	Check or change the temp. sensor
Syst1:Pressure Sensor fault	PP11	The system 1 pressure Sensor is broken or short circuit	Check or change the pressure sensor or pressure
Syst2:Coil temp Sensor	P25	The temp. Sensor is broken or short circuit	Check or change the temp. sensor
Syst2:Suction temp Sensor	P27	The temp. Sensor is broken or short circuit	Check or change the temp. sensor
Syst2:Antifreeze Sensor1(US)	P291	The temp. Sensor is broken or short circuit	Check or change the temp. sensor
Syst2:Antifreeze Sensor2(US)	P293	The temp. Sensor is broken or short circuit	Check or change the temp. sensor
Syst2:Antifreeze Sensor1(HSS)	P292	The temp. Sensor is broken or short circuit	Check or change the temp. sensor
Syst2:Antifreeze Sensor2(HSS)	P296	The temp. Sensor is broken or short circuit	Check or change the temp. sensor
Syst2:Exhaust Temp Sensor	P281	The temp. Sensor is broken or short circuit	Check or change the temp. sensor
Syst2:Pressure Sensor fault	PP21	The system 2 pressure Sensor is broken or short circuit	Check or change the pressure sensor or pressure
Syst2:Inlet Sensor(EVI)	P201	The temp. Sensor is broken or short circuit	Check or change the temp. sensor
Syst2:Outlet Sensor(EVI)	P202	The temp. Sensor is broken or short circuit	Check or change the temp. sensor
Syst1:Exhaust Overtemp	P182	The temp. Sensor is broken or short circuit	Check or change the temp. sensor
Syst2:Exhaust Overtemp	P282	The temp. Sensor is broken or short circuit	Check or change the temp. sensor
Low ATProtection	TP	The ambient temp. is low	
Fan Motor1 Fault	F031	1. Motor is in locked-rotor state 2.The wire connection between DC-fan motor module and fan motor is in bad contact	1. Change a new fan motor 2. Check the wire connection and make sure they are in good contact
Fan Motor2 Fault	F032	1. Motor is in locked-rotor state 2.The wire connection between DC-fan motor module and fan motor is in bad contact	1. Change a new fan motor 2. Check the wire connection and make sure they are in good contact
Communication Fault (speed control module)	E081	Speed control module and main	Check the communication connection
Communication Fault	E08	Communication failure between wire controller and mainboard	Check the wire connection between remote wire controller and main board
Syst1:Comp Overcurrent	E101	The compressor is overload	Check if system of compressor running normally
Syst2:Comp Overcurrent	E201	The compressor is overload	Check if system of compressor running normally
Syst1: HP Protection	E11	The high-pressure switch is broken	Check the pressure switch and cold circuit
Syst2: HP Protection	E21	The high-pressure switch is broken	Check the pressure switch and cold circuit
Syst1: LP Protection	E12	The high-pressure switch is broken	Check the pressure switch and cold circuit
Syst2: LP Protection	E22	The high-pressure switch is broken	Check the pressure switch and cold circuit
Flow Switch Protection	E032	No water/little water in water system	Check the pipe water flow and water pump
Aux Superheat Protection	E04	Electric-heater protection switch is broken	Check to see if the electric heater has been running under the temperature over 150 for a long time
Prim Anti-freezing Prot	E19	The ambient temp. is low	
Secondary Anti-freezing Prot	E29	The ambient temp. is low	
Syst1:Antifreeze(US)	E171	Use side water system temp. is low	1. Check US water temp. or change temp. sensor 2.Check pipe water flow and whether water system is jammed or not
Syst2:Antifreeze(US)	E271	Use side water system temp. is low	1. Check US water temp. or change temp. sensor 2.Check pipe water flow and whether water system is jammed or not
Syst1:Antifreeze(HSS)	E172	Heat side water system temp. is low	1. Check HSS water temp. or change temp. sensor 2.Check pipe water flow and whether water system is jammed or not
Syst2:Antifreeze(HSS)	E272	Heat side water system temp. is low	1. Check HSS water temp. or change temp. sensor 2.Check pipe water flow and whether water system is jammed or not
Syst1:Exhaust Overtemp	E182	The compressor is overload	Check whether the system of the compressor running normally
Syst2:Exhaust Overtemp	E282	The compressor is overload	Check whether the system of the compressor running normally
Excess Water Temp Diff	E06	Not enough water flow, low pressure difference	Check pipe water flow & if water system is jammed

7. Appendix

7.1 Parameter List

Meaning	Default	Remarks
Cooling target temperature set point	12°C	Adjustable
Heating the target temperature set point	40°C	Adjustable
Hot Water target temperature set point	55°C	Adjustable

7.2 Cable Specifications

Nameplate maximum current	Phase line (Single Phase)	Phase Line (Three Phase)	Earth line	MCB	Creepage Protector	Signal Line
No more than 10A	2 x 1.5mm ²	3 x 1.5mm ²	1.5mm ²	20A	30mA less than 0.1 sec	n x 0.5mm ²
10~16A	2 x 2.5mm ²	3 x 2.5mm ²	2.5mm ²	32A		
16~25A	2 x 4mm ²	3 x 4mm ²	4mm ²	40A		
25~32A	2 x 6mm ²	3 x 6mm ²	6mm ²	40A		
32~40A	2 x 10mm ²	3 x 10mm ²	10mm ²	63A		
40~63A	2 x 16mm ²	3 x 16mm ²	16mm ²	80A		
63~75A	2 x 25mm ²	3 x 25mm ²	25mm ²	100A		
75~101A	2 x 25mm ²	3 x 25mm ²	25mm ²	125A		
101~123A	2 x 35mm ²	3 x 35mm ²	35mm ²	160A		
123~148A	2 x 50mm ²	3 x 50mm ²	50mm ²	225A		
148~186A	2 x 70mm ²	3 x 70mm ²	70mm ²	250A		
186~224A	2 x 95mm ²	3 x 95mm ²	95mm ²	280A		

7.3 Wire Control Interface Diagram



Sign	Meaning
V	12v (power +)
R	No Use
T	No Use
A	485A
B	485B
G	GND (power-)

7.4 Wiring Diagrams

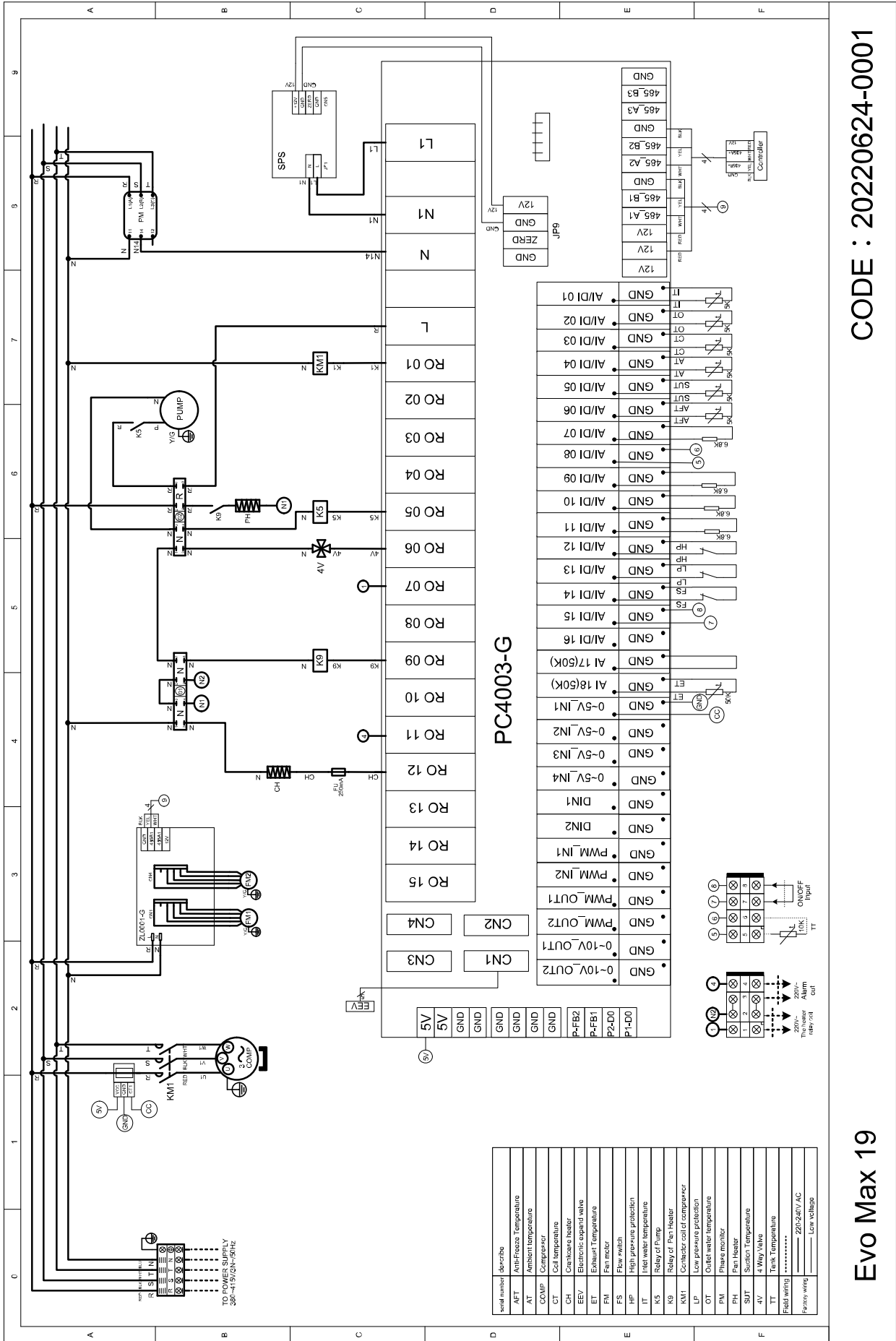

CODE : 20220624-0001

Evo Max 19

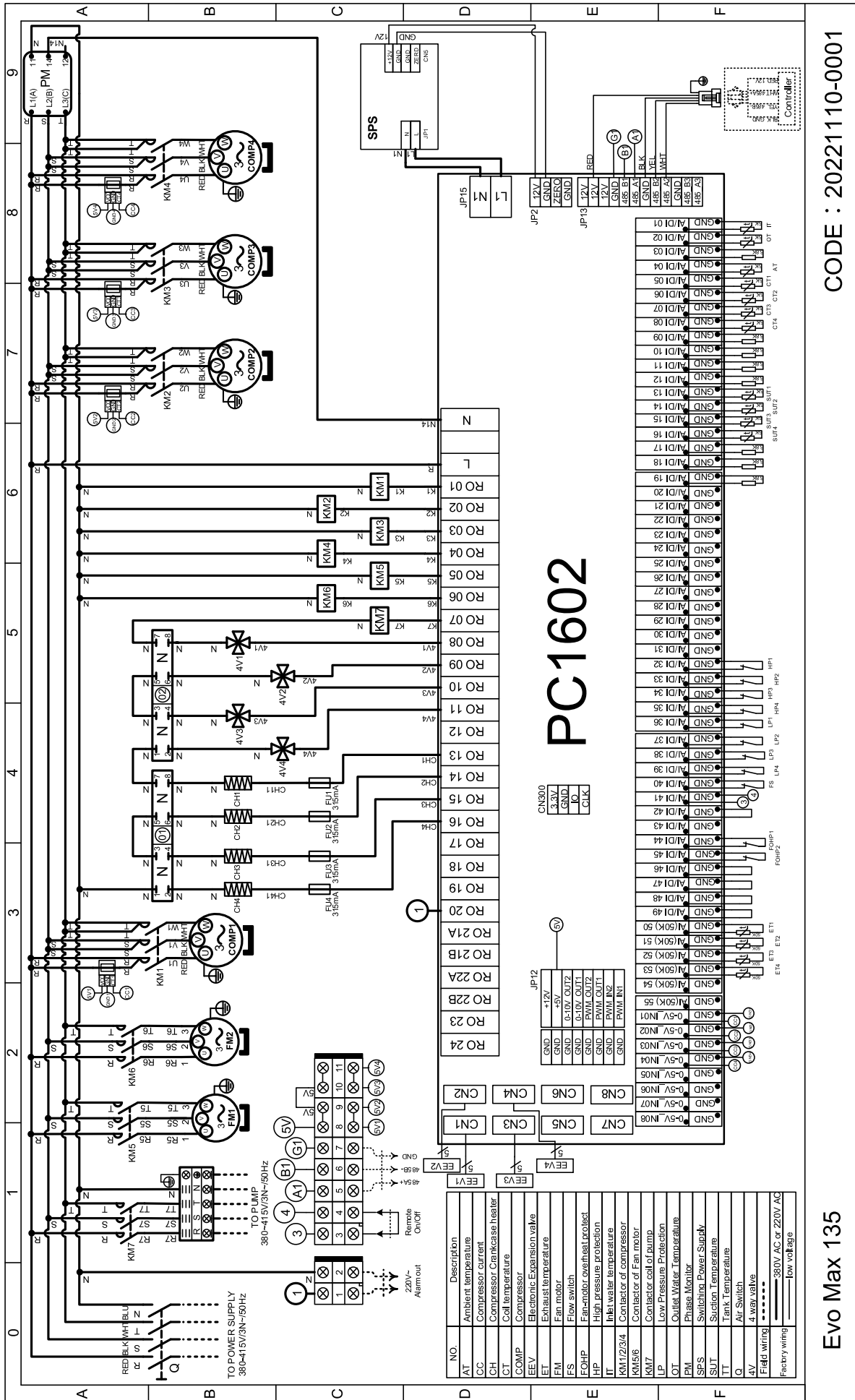

CODE : 20221110-0001

Evo Max 135

8. Maintenance



DO I NEED TO GET MY UNIT SERVICED?

It is recommended that you get your EvoHeat unit serviced once a year by your local certified air conditioning or refrigeration technician. If your unit is located in a coastal area, more frequent maintenance may be necessary. During the service, they will check the operational pressures of the refrigeration system and give the unit and fins a good clean to ensure maximum performance.



DO WE HAVE RECOMMENDED SERVICE AGENTS?

EvoHeat have a large database of recommended service agents. Please contact EvoHeat tech support on 1300 859 933 for your local service agent details.



SHOULD I CHECK MY UNIT REGULARLY?

We recommend you check your unit regularly to avoid potential issues and damage to your heat pump.

Check the water inlet/outlets often for leaks. You should avoid the condition of no water or air entering into the system, as this will influence unit's performance and reliability.

The area around the unit should be dry, clean and well ventilated. Make sure there is nothing blocking the airflow of the heater e.g. Leaf litter. Clean the heat exchanger every few months to keep a good heat exchange rate and save energy.



WHAT SHOULD I BE CHECKING REGULARLY?

You should discharge the water at the bottom of the water pump if the unit will not be used for an extended period. Discharge all water in the water pump and water system so that freezing of the water in the pump or water system does not occur. Check the unit thoroughly and fill the system with water fully before using it for the first time after a period of time.

Check the power supply and cable connection often, should the unit begin to operate abnormally, switch it off and contact the qualified technician

Clean the water filter periodically to maintain good water quality. Lack of water and dirty water can damage the unit. The heat pump will start the water every 72 hours when it is not running to avoid freezing.

The water loop of the heat pump MUST be protected from freezing in winter. Do not shut off the power supply to the heat pump in winter. When the air temperature is below 0°C, if the inlet water temperature is above 2°C and below 4°C the water pump will begin freezing protection. If the inlet water is lower than 2°C, the heat pump will begin heating.

9. Warranty



Refer to the EvoHeat website for warranty details

Australia:

<https://evoheat.com.au/warranty-terms/>

REGISTER YOUR WARRANTY



EvoHeat highly recommend customers complete their warranty details online to ensure efficient warranty claim processing. To register your warranty, scan our QR Code or head to our website and fill in the Warranty Registration Form: <https://evoheat.com.au/warranty-registration/>

1. Warranty terms are from date of purchase.
2. This warranty excludes any defect or injury caused by or resulting from misuse, abuse, neglect, accidental damage, improper voltage, vermin infestation, incompetent installation, any fault not attributable to faulty manufacture or parts, any modifications which affect the reliability or performance of the unit.
3. This warranty does not cover the following:
 - a) Natural Disasters (hail, lightening, flood, fire etc.)
 - b) Damage resulting from any animal or creature (including vermin, reptiles and insects)
 - c) Rust or damage to exterior coatings, materials, and cabinet caused by corrosive atmosphere or weather/environmental conditions.
 - d) When serviced by an unauthorised person without the permission of Evo Industries.
 - e) When a unit is installed by an unqualified person.
 - f) When failure occurs due to improper or incorrect installation.
 - g) Where failure occurs due to failure of any other equipment connected in relation with the EvoHeat unit (e.g. power supply, water pump etc.).
 - h) Where failure occurs due to improper maintenance or misuse (refer Operating Instructions).
 - i) Where the unit has not had its three-year general maintenance service performed by a certified plumber. Proof of this service will be required for warranty claims beyond three years.
 - j) 'No Fault Found' service calls where the perceived problem is explained within the operation instructions.
 - k) Costs associated with delivery, handling, freighting, or damage to the product in transit.
 - l) Where the unit has been relocated from its originally installed location.
4. If warranty service is required, you should:
 - a) Contact Evo Industries Australia on 1300 859 933 or via our Contact page on our website.
 - b) Provide a copy of your receipt as proof of purchase.
 - c) Have completed the online Service Request Form via the website www.evoheat.com.au/service-request/
5. Onsite technical service is available within the normal operating area of your Evo Authorised Service Agents. Service outside this area will incur a traveling fee.
6. Our goods come with guarantees that cannot be excluded under the Australian Consumer Law. You are entitled to a replacement or refund for a major failure and compensation for any other reasonably foreseeable loss or damage. You are also entitled to have the goods repaired or replaced if the goods fail to be of acceptable quality and the failure does not amount to a major failure.